

**2**

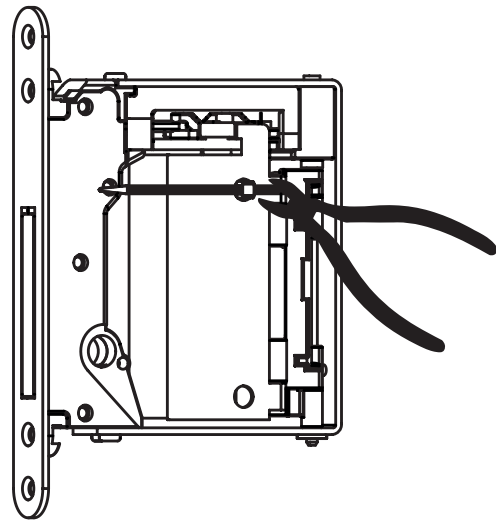

**3**

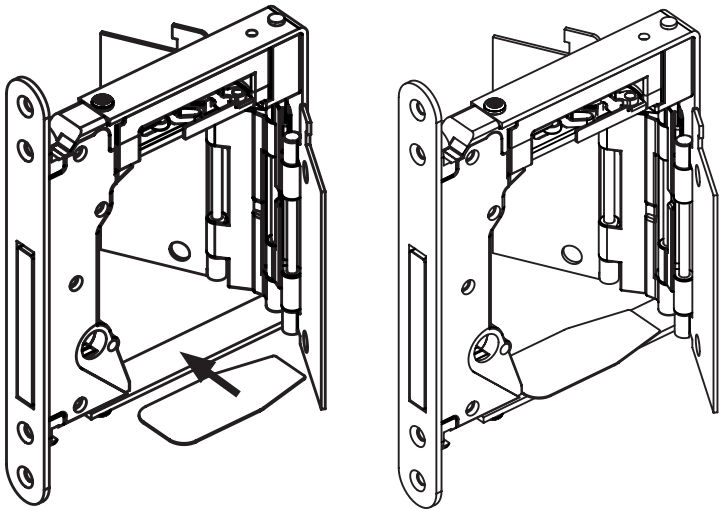

**4**

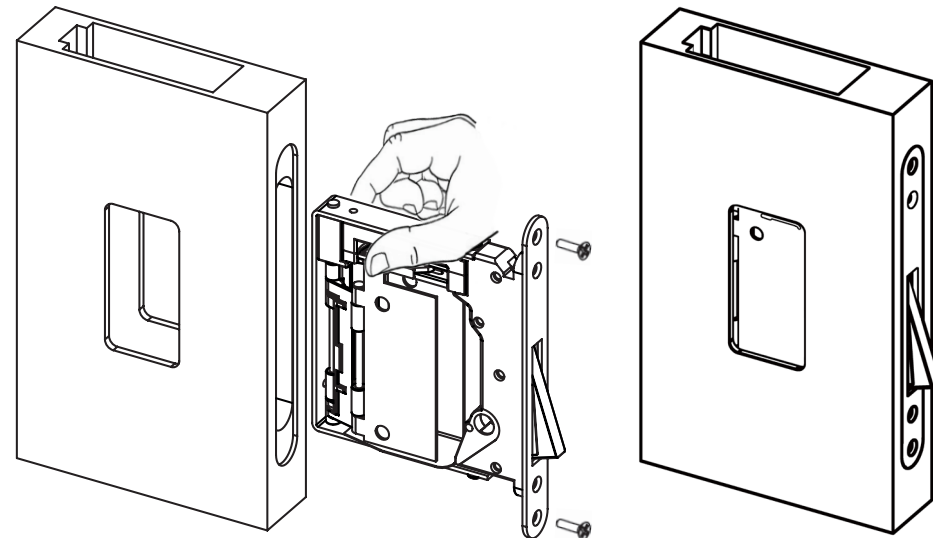

**5**

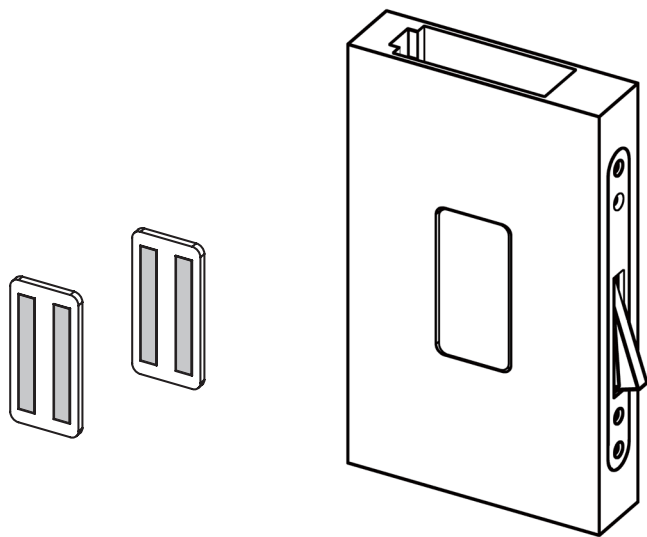

**6**

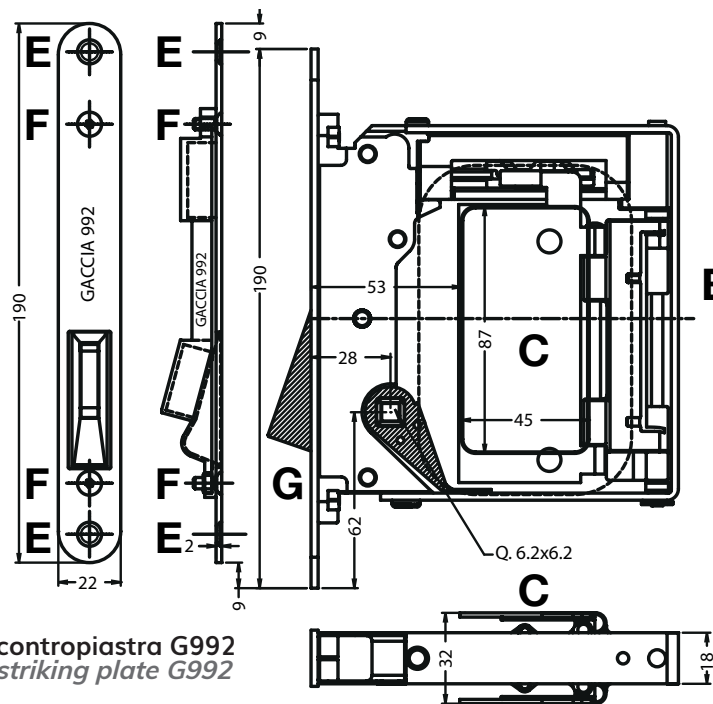

contropiastra G992  
striking plate G992

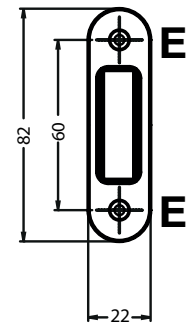
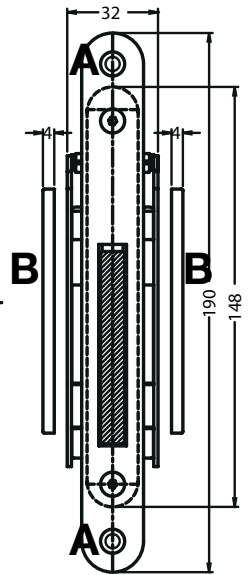

contropiastra GR95  
striking plate GR95

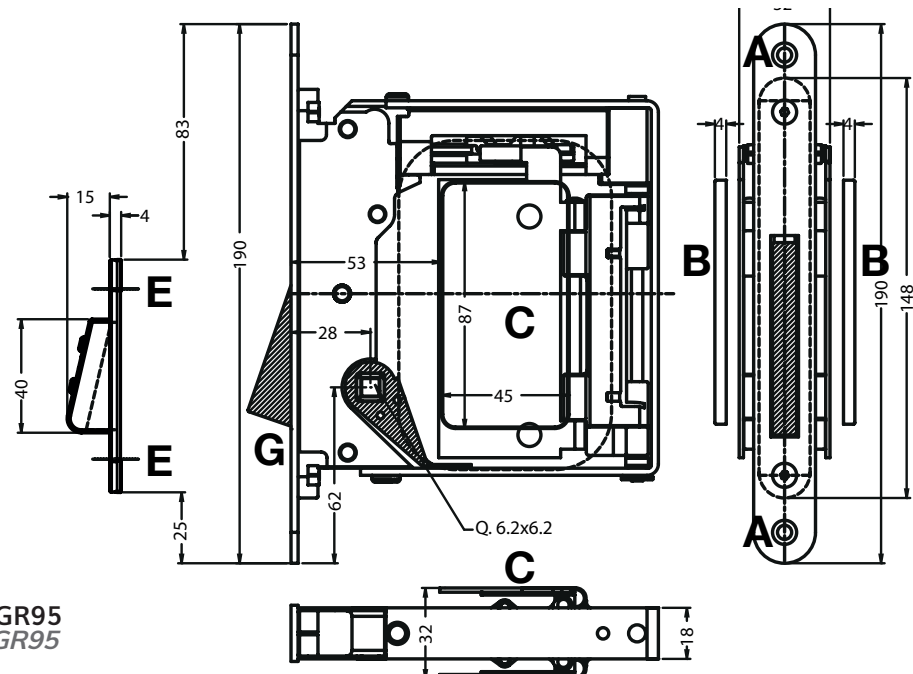



# NO-HA MINI Invisible lock INSTALLATION INSTRUCTIONS



**WARNING** THE NO-HA MINI LOCK CAN BE FITTED ON A TRADITIONAL DOOR, BUT A PARTICULAR MILLING PROCEDURE IS REQUIRED IN ORDER TO CREATE THE SPACE FOR THE DEVICE **1**

## INSTALLATION PROCEDURE

- 2** Apply the two finger-rest H inside the cavity, using the long adhesive tapes.
- 3** Remove the band which blocks the two flap plates.
- 4** Apply the black cover (only aesthetic function).
-  Lubricate with grease the external part of the brass triggers.
- 5** Insert the lock holding the two flap plates.  
Check the correct function of two lateral flap plates.  
Fasten the lock with the 2 screws A on the door.
- 6** Put the two short adhesive tapes on the back of each cover C (not included, to be purchased separately).
- 7** Verify the correct operation of the lock as follows:
  - a) pull the oscillating latch G out of the front plate by pushing its upper side
  - b) engage the plate-cover B; the latch G must retract
  - c) put the striking plate G992 or GR95 opposite to the front plate; the latch (G) must come out.
- 8** Fasten the striking plate on the frame with the screws E (not included).  
Check the door closing and, if needed, adjust the position of the striking plate acting on screws (F).



tecnic@bonaiti.it

**1**

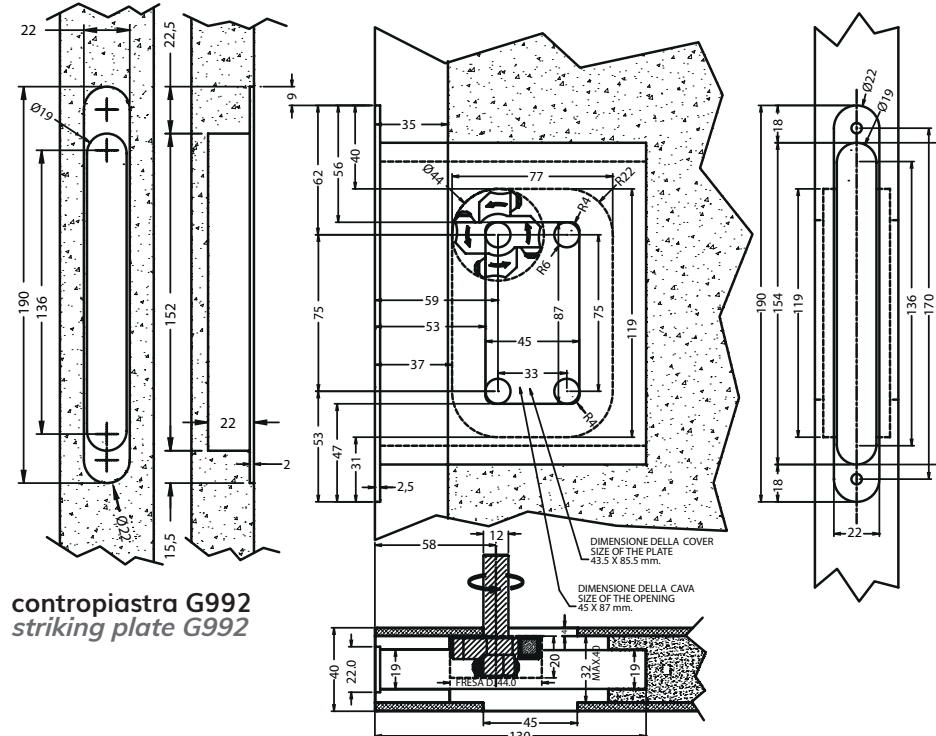

contropiastra G992  
striking plate G992

**1**

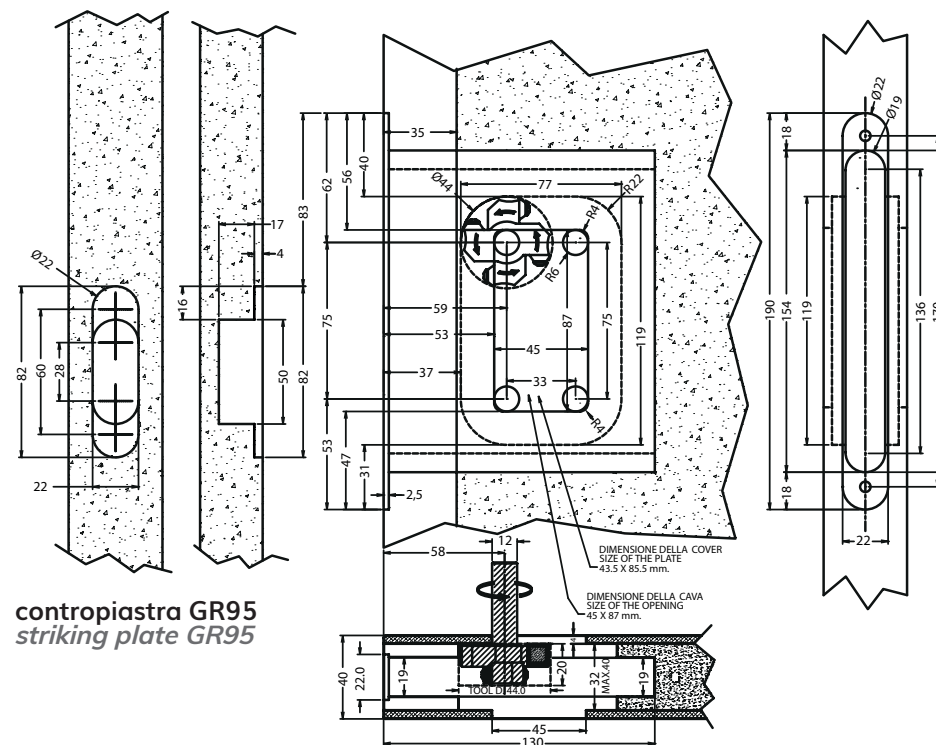

contropiastra GR95  
striking plate GR95



# Serratura NO-HA MINI ISTRUZIONI DI MONTAGGIO



**ATTENZIONE** LA SERRATURA NO-HA MINI PUÒ ESSERE INSTALLATA SU UN PANNELLO TRADIZIONALE, NECESSITA PERÒ DI UNA FRESATURA PARTICOLARE CHE ACCOLGA IL MECCANISMO DI FUNZIONAMENTO **1**

## PROCEDURA DI MONTAGGIO

- 2** Applicare i due appoggia dita H all'interno della cava, utilizzando i biadesivi lunghi.
- 3** Tagliare la fascetta che blocca le due palette in acciaio.
- 4** Applicare il copritelai (funzione solo estetica).
-  Lubrificare con del grasso la parte esterna delle levette in ottone.
- 5** Inserire la serratura tenendo strette le due palette in acciaio.  
Controllare il corretto funzionamento delle due palette in acciaio.  
Fissare la serratura al pannello porta con le 2 viti A.
- 6** Applicare i due biadesivi corti sul retro di ciascuna cover C (queste sono da comprare separatamente).
- 7** Verificare il corretto funzionamento della serratura nel seguente modo:
  - a) estrarre l'oscillante G dal frontale premendo la parte superiore dello stesso
  - b) azionare la cover B; l'oscillante G deve rientrare
  - c) posizionare la contropiastra GR95 o G992 davanti al frontale; l'oscillante G deve uscire.
- 8** Fissare la contropiastra con le apposite viti E (non incluse).  
Provare la chiusura della porta ed effettuare eventuali regolazioni sulla contropiastra con le viti F.



tecnic@bonaiti.it