

## Basic programme for standard applications

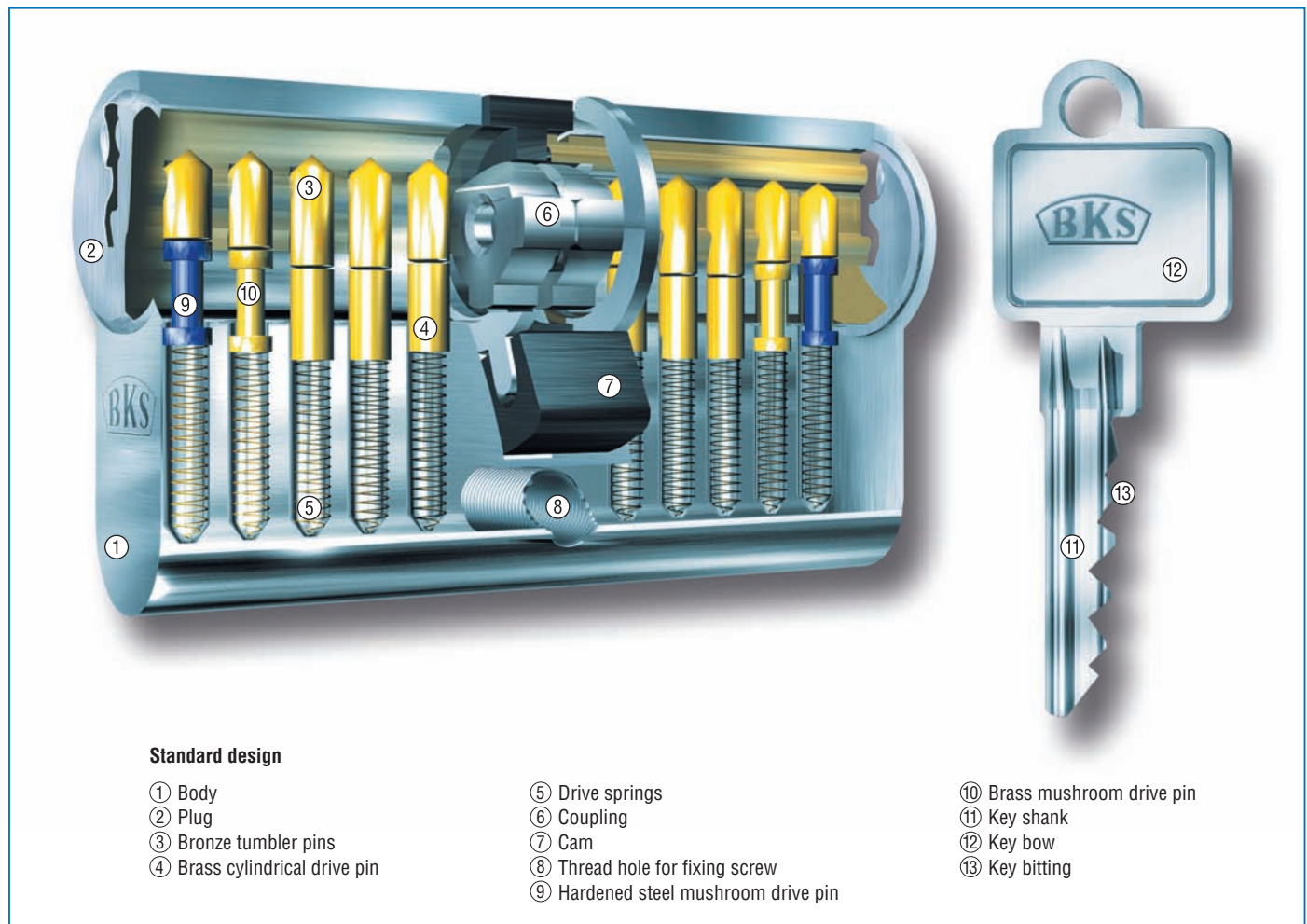

### BKS locking cylinder series according to DIN EN 1303 and DIN 18252

5 pin profile cylinder with paracentric key profile, for **single differ and keyed alike locking**. Brass cylinder body finished matt nickel or satin brass, with 3 steel keys, without escutcheons, with nickel plated steel fixing screw M5 x 80 mm.

## Overview of cylinder variants

Double cylinder 8800

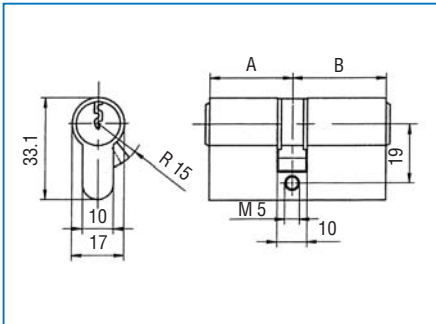

Half cylinder 8900

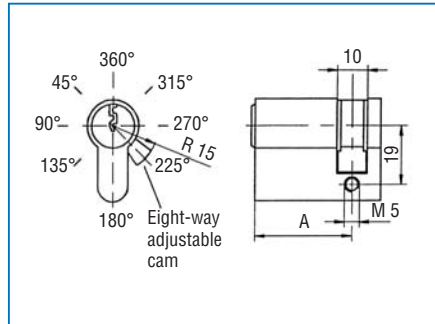

Blank key B 4135 0701

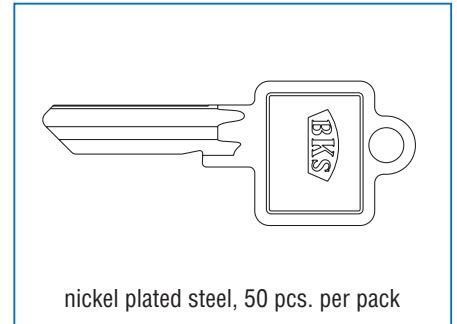

Knob cylinder 8804

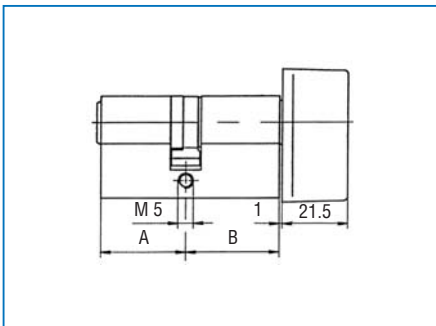

Knob cylinder 8806

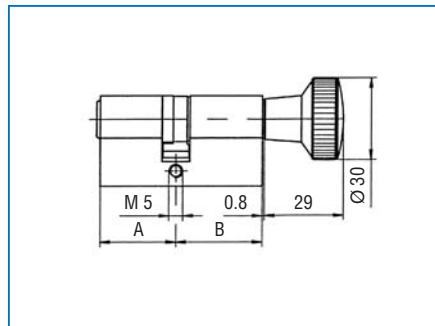

Additional compatible versions e.g. cam cylinders, rim locks and special cylinders are available in series 31.

### Options and advice:

**Emergency function** Optional from BL 31/31 on both sides, from BL 27/31 on one side. The emergency function on double cylinders allows the cylinder to be operated even if a key is inserted on the other side of the cylinder.

**Drill protection** Available with optional certificated drill protection BSKA (two pairs of electro-plated hardened steel pins on each side of cylinder).

**SKG approval** Double, half and knob cylinders with  certification available on request.

We recommend the use of pre-mounted service cylinders. With these you can easily produce sets of keyed alike cylinders. Please consult us for further information.